

LAND

AMETEK®

**WASTE
INCINERATION
APPLICATION NOTE**



SOLID WASTE



LIQUID WASTE



SEWAGE SLUDGE

INTRODUCTION

Waste incineration is commonly used to dispose of the organic components of both domestic refuse and hazardous waste by burning it under controlled conditions. The heat generated in this process can be used to generate electricity, a process known as Waste-To-Energy (WTE).

Because they have the potential to release highly toxic chemicals, such as polyaromatic hydrocarbons (PAH) and heavy metals, waste incinerators are subject to stringent environmental regulations.

Temperature and emissions monitoring equipment provides the continuous data required to

ensure complete burn-up of the waste materials and minimise regulated emissions.

AMETEK Land supplies accurate, reliable solutions across all stages of the combustion process. A comprehensive range of instruments monitor emissions and ensure maximum destruction of the waste.

MUNICIPAL SOLID WASTE INCINERATOR

Municipal solid waste (MSW) disposal plants incinerate domestic garbage and use the heat released to generate electricity. Precise measurements support the optimisation of this process and also help to control emissions. In addition, thermal furnace monitoring within the boiler provides essential information on the refractory wall, slag, and flame conditions.

The most common type uses a moving-grate boiler to move the waste through the combustion chamber and ensure adequate residence time to achieve

maximum destruction. In Europe, the Industrial Emissions Directive (IED) specifies a minimum residence time of two seconds at 850 °C (1562 °F) to achieve complete destruction of toxic organic material.

Because of the nature of the fuel, the feed system for the MSW does not always provide an even flow of refuse onto the grate, and it is challenging to view burning material for a consistent fuel flow rate. Environmental regulations require emissions of gases and

particulate matter to be measured and reported, to demonstrate compliance.

The advanced products developed by AMETEK Land provide solutions to support combustion control and emissions monitoring, which together lower process costs and avoid fines for non-compliance. Accurate, non-contact measurements support optimal conditions without interfering with the combustion process. Boiler monitoring can help identify maintenance issues at an early stage to enable mitigating measures to be implemented.

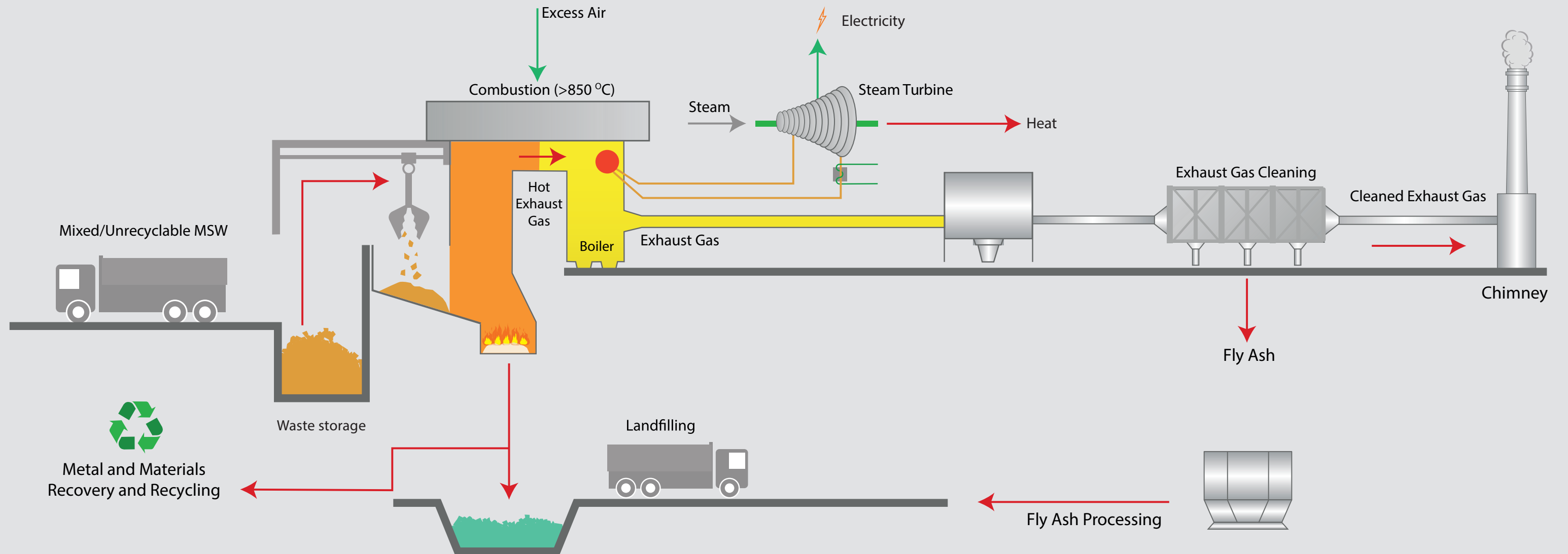

FURNACE THERMAL IMAGING

Advanced furnace thermal imaging in the boiler overcomes the extreme heat to monitor interior conditions and optimise the combustion process. AMETEK Land's MWIR-B-640 borescope thermal imager can be used to view the burner grates through a small peephole in the boiler wall.

Because of the specific wavelength used, the MWIR-B-640 is insensitive to luminous flames and can provide a clear image, through existing smoke and particles (soot), of the material on the grate, monitoring the feed system and grate operation, continuously monitoring the refractory and heat exchanging tubes conditions and helping to improve thermal efficiency.

MAIN PRODUCTS

MWIR-B-640

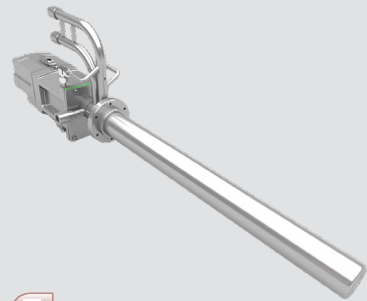

Process Imaging

ADDITIONAL PRODUCT

NIR-B NIR-B-2K



Process Imaging

GAS & EMISSION MONITORING

Control of the process is also supported by measuring carbon monoxide (CO) emissions and acid dewpoint. Flue gas detection is required to ensure plants comply with

emissions regulations. Depending on the emission limit value, an opacity monitor or PM-CEMS is used to monitor particulate matter emissions from the stack.

MAIN PRODUCTS

LANCOM 4



Combustion & Emission Monitoring

LANCOM 200



Combustion & Emission Monitoring

FURNACE GAS TEMPERATURE - CDB



4500 MKIII



Combustion & Emission Monitoring

4650-PM



Combustion & Emission Monitoring



Fixed Spot Thermometers

WASTE STORAGE MONITORING

Typically, prior to the waste combustion process, the waste from different sources is stored inside in piles. To reduce the risk of a fire, extinguishing systems are installed. While these systems put out an existing fire, thermal imaging based hot spot motoring/pile monitoring provides a continuous monitoring and localisation of hot spots for early detection of possible fires and localized measures to extinguish such fires.

MAIN PRODUCT

LWIR-640



Process Imaging

LIQUID ORGANIC WASTE INCINERATION AT HAZARDOUS WASTE PLANTS

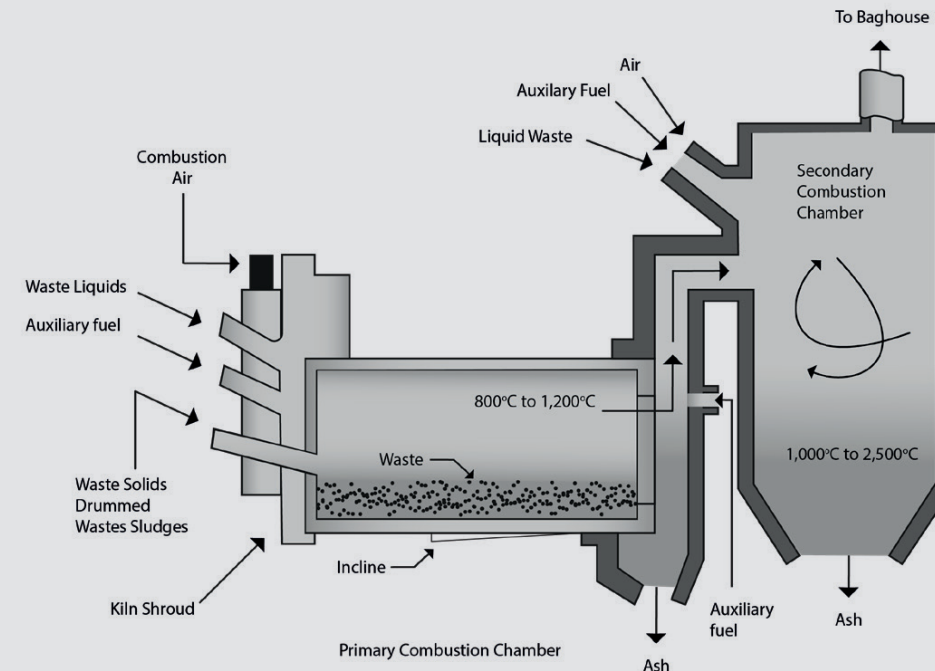

Hazardous organic chemical wastes are destroyed by high-temperature incineration in a rotary kiln. The high temperature and extended residence time in the kiln ensure full destruction of the material.

To meet the regulated disposal requirements, specific temperature and time limits must be maintained to ensure complete destruction of material. Thermocouples and conventional thermometers are unable to measure the gas temperature throughout the combustion chambers and within the kiln accurately.

The NIR-B-656/2K or MWIR-B-640 borescope imagers provide a wide thermal image and temperature map

of the area close to the burner and the furnace/refractory, delivering temperature feedback for the combustion process and conditions and the burner controls. The CDB thermometer is optimised to accurately measure the true gas temperature in boilers and incinerators using AMETEK Land's unique non-contact infrared technology.

Alternatively, a SPOT+ pyrometer, mounted outside the kiln using thermowell through the kiln wall, measures the temperature further along the kiln, giving an interior temperature measurement within this hazardous environment.

MAIN PRODUCTS

NIR-B-656/2K

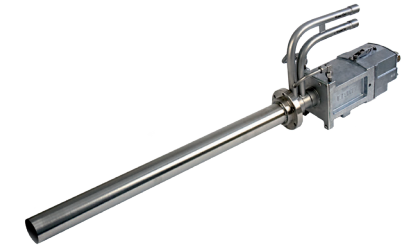

Process Imaging

MWIR-B-640

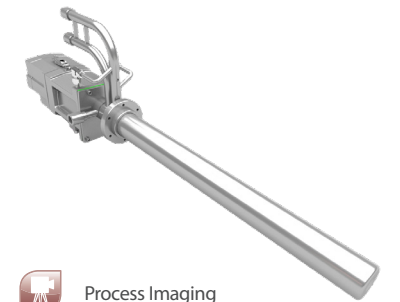

Process Imaging

FURNACE GAS TEMPERATURE - CDB

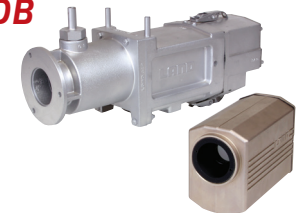

Fixed Spot Thermometers

ADDITIONAL PRODUCT

SPOT+



Fixed Spot Thermometers

SEWAGE SLUDGE INCINERATOR

The solid residues from sewage treatment are destroyed by burning in an incinerator. Multiple-hearth and fluidised bed designs are the most common types. Because of its low heat capacity, additional fuel is needed to burn sewage sludge, so Waste to Energy (WTE) is not possible in this application.

The flue gases are scrubbed of particles, acid gases and, finally, mercury. The preferred method for mercury removal is to pass the gases through a scrubber containing powdered activated carbon (PAC).

However, PAC oxidises readily and can catch fire if it becomes overheated.

A twin-stream Millwatch measures the carbon monoxide concentration at the inlet and outlet of the PAC scrubber. A significant increase in the CO concentration at the scrubber outlet is an indication that the PAC is beginning to ignite, and that action needs to be taken to prevent a fire.

MAIN PRODUCT

MILLWATCH



Combustion & Emission Monitoring

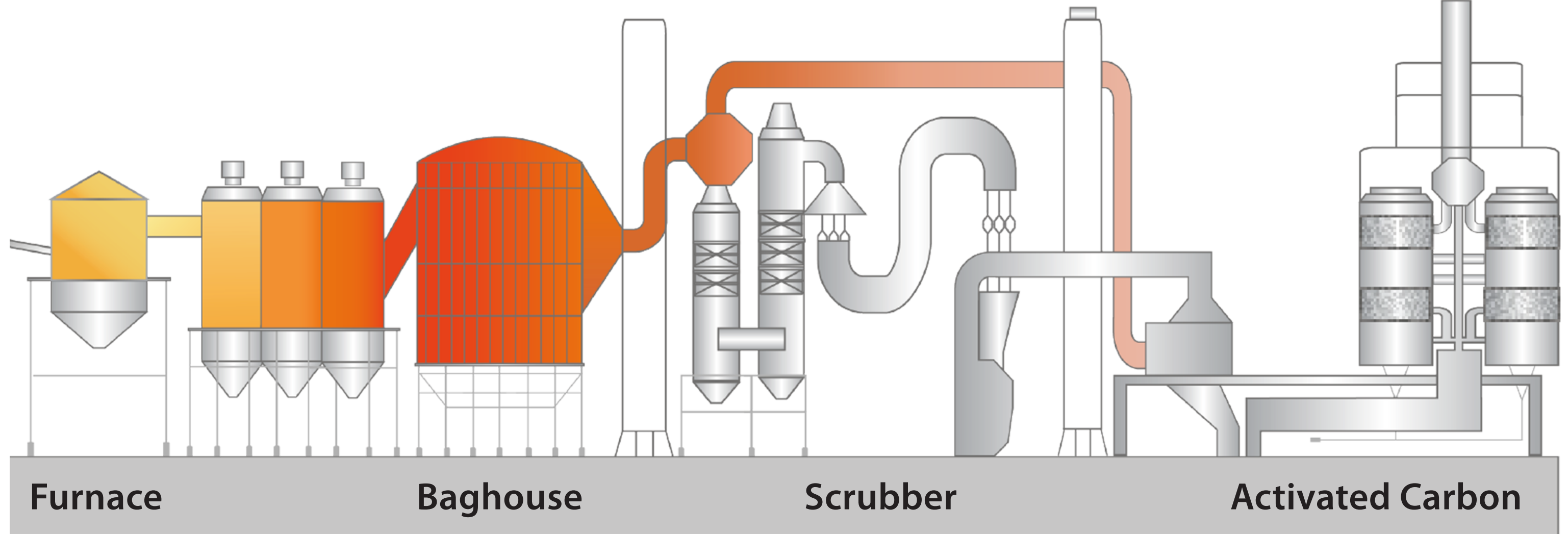

CONVEYOR OPERATIONS

Waste for combustion can be moved from a waste storage area to the furnace by a conveyor belt. Since the composition of the waste is often unknown and the additional presence of atmospheric oxygen, there may be hot inclusions that can damage the conveyor belt or cause a larger fire. This causes safety issues and risks unplanned downtime.

The danger of hot spots in the waste is increased if industrial or hazardous

waste is used. Continuous and fast hot spot scanning provides an automated detection system that links to process controls to deal with these hot spots before fire damage occurs.

Fast-response detection of hot spots in the waste fuel on the conveyor belt prevents damage to plant equipment and costly process shutdowns. Alarm outputs can trigger an automated fire suppression response for added safety.



MAIN PRODUCT

HOTSPOTIR



Linescanning

STACK EMISSIONS

Waste plants are subject to strict environmental regulations because of their potential to cause severe environmental damage.

To ensure compliance with emission limits placed by governments around the world, waste incinerators are required to monitor and control their

stack gas emissions. Emissions of particulate matter (PM) are an indication of a poorly controlled process and are correlated with emissions of highly toxic heavy metals.

Continuous emissions monitoring helps ensure that incinerators meet the necessary control regulations,

avoiding the prospect of sizeable fines. In some cases, this monitoring supports the improvement of operational efficiency, lowering operating costs. It can also reduce damage to the plant, extending equipment life.

MAIN PRODUCTS

4500 MKIII



Combustion & Emission Monitoring

4650-PM

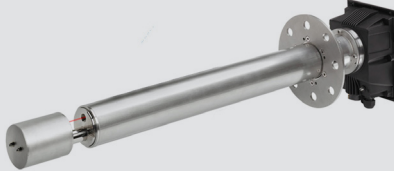

Combustion & Emission Monitoring

ADDITIONAL PRODUCT

4400

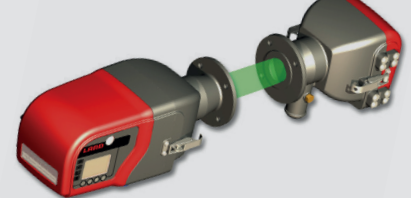

Combustion & Emission Monitoring

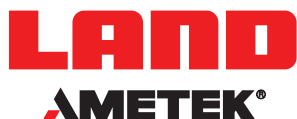

CONTACT US



www.ametek-land.com



land.enquiry@ametech.com



We are fully committed to Quality Assurance. See all our accreditations at AMETEK-LAND.COM/QUALITY